

SCOTT MILLER & the COMMONWEALTH TECH (for 5 piece)

INPUT LIST	
1. VOCAL - Stage left	E385 or similar
2. VOCAL - Scott	E385 or similar
3. VOCAL - Rayna	E385 or similar
4. VOCAL - Bryn	E385 or similar
5. Electric amp (guitar, stage L)	SM57
6. Acoustic amp (Scott acoustic)	SM57
7. Electric amp (Scott electric)	SM57
8. XLR (for fiddle Di)	
9. Acoustic amp (fiddle amp)	SM57
10. XLR (bass amp)	
DRUM MICS	
11. Kick	M88
12. Snare	SM57
13. Hi Hat	SM81
14. Rack	EV408
15. Floor	EV408
16. Overhead	SM81
17. Overhead	SM81

OTHER TECH NEEDS
• Power for (1-2) pedals and (3-7) amps
• Small table for Scott
• Drum rug

STAGE LEFT

FRONT OF STAGE

STAGE RIGHT

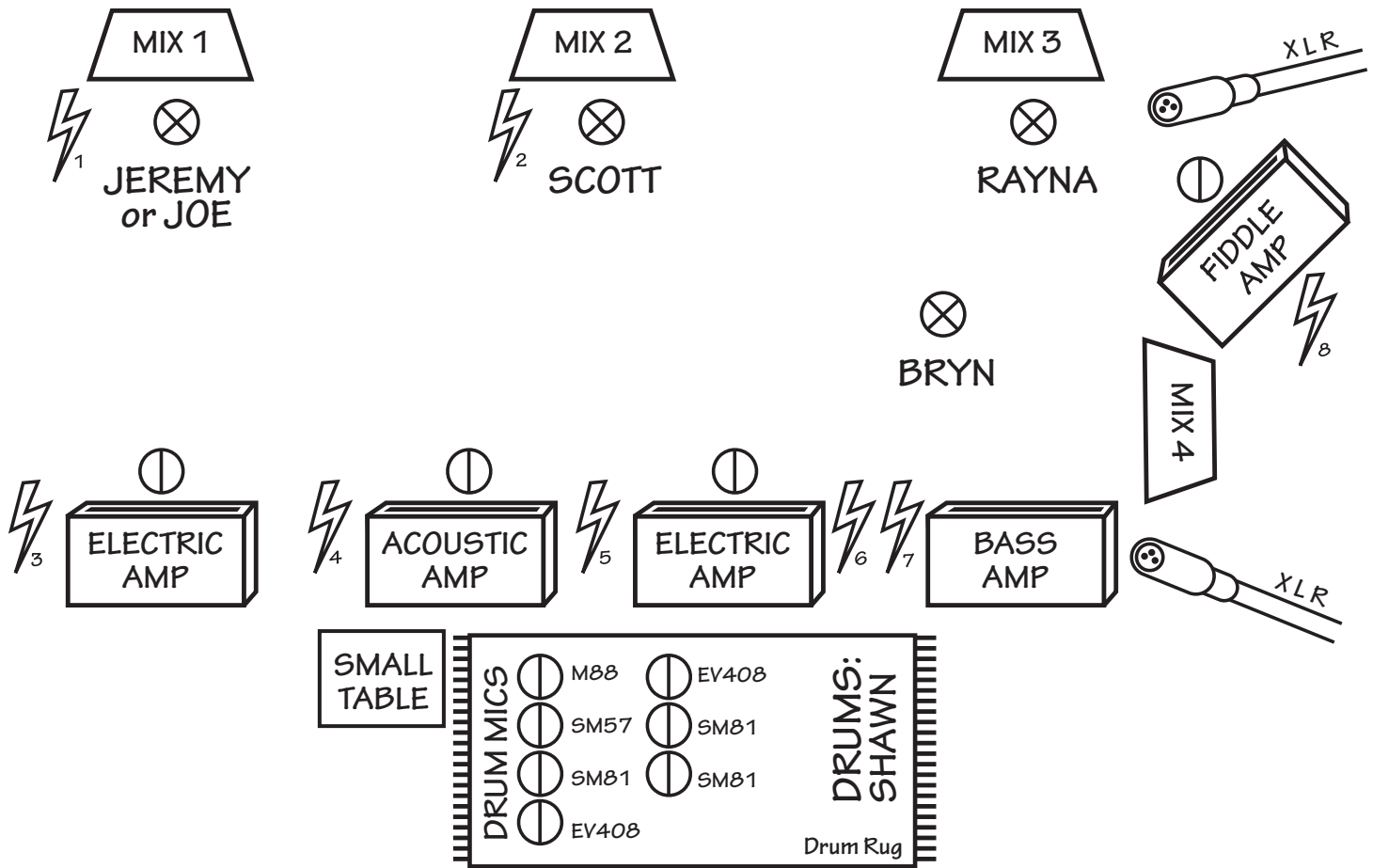

KEY					
	VOCAL MIC E385 or similar		INSTRUMENT MIC As specified		XLR CABLE
	ELECTRICITY		AMPLIFIER		MONITOR